

EN

Generator Installation and Operating Manual

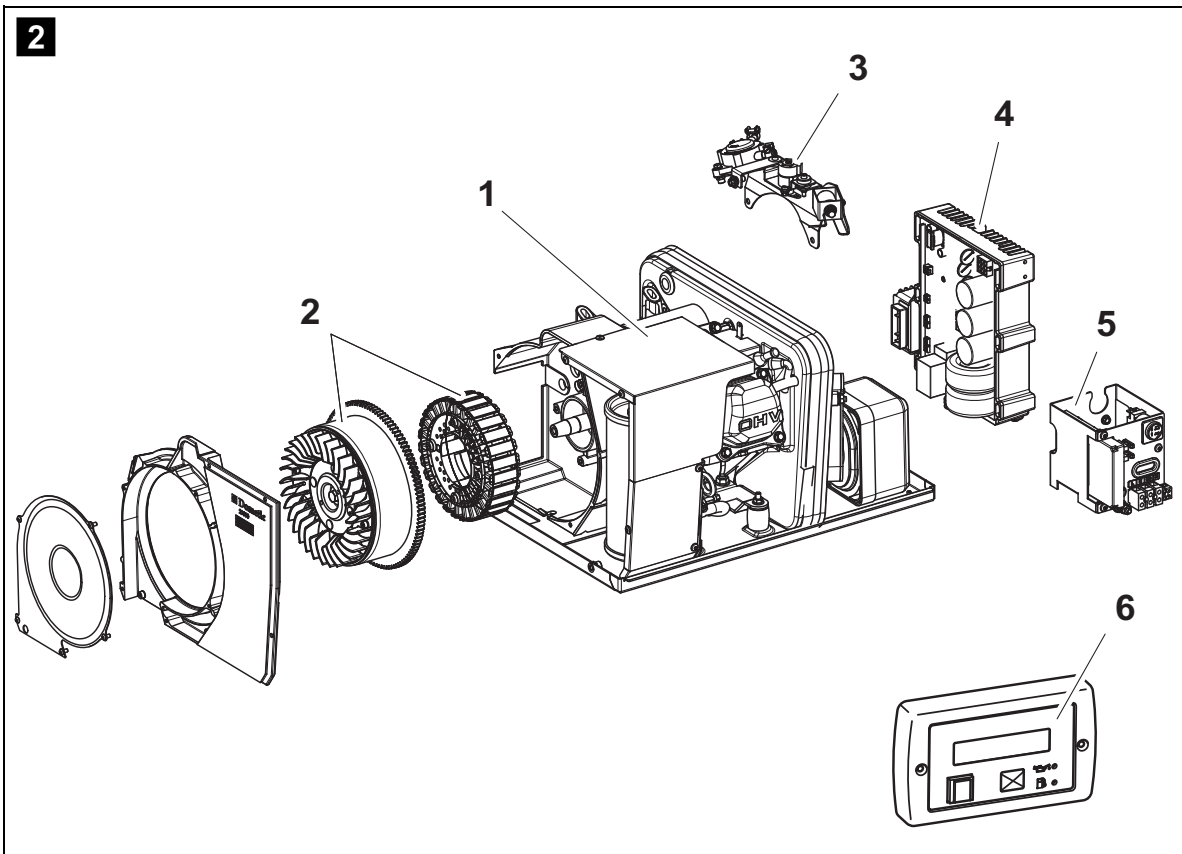

Dometic TEC 29 EV AUS

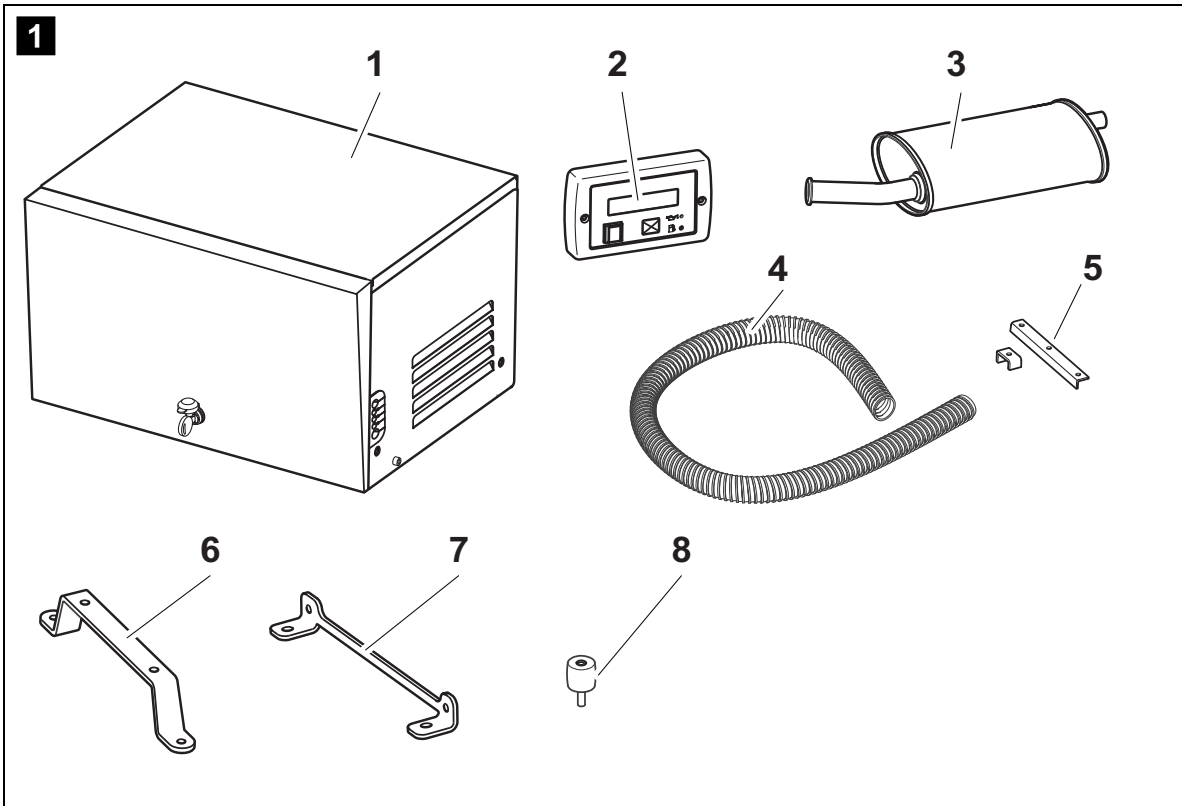

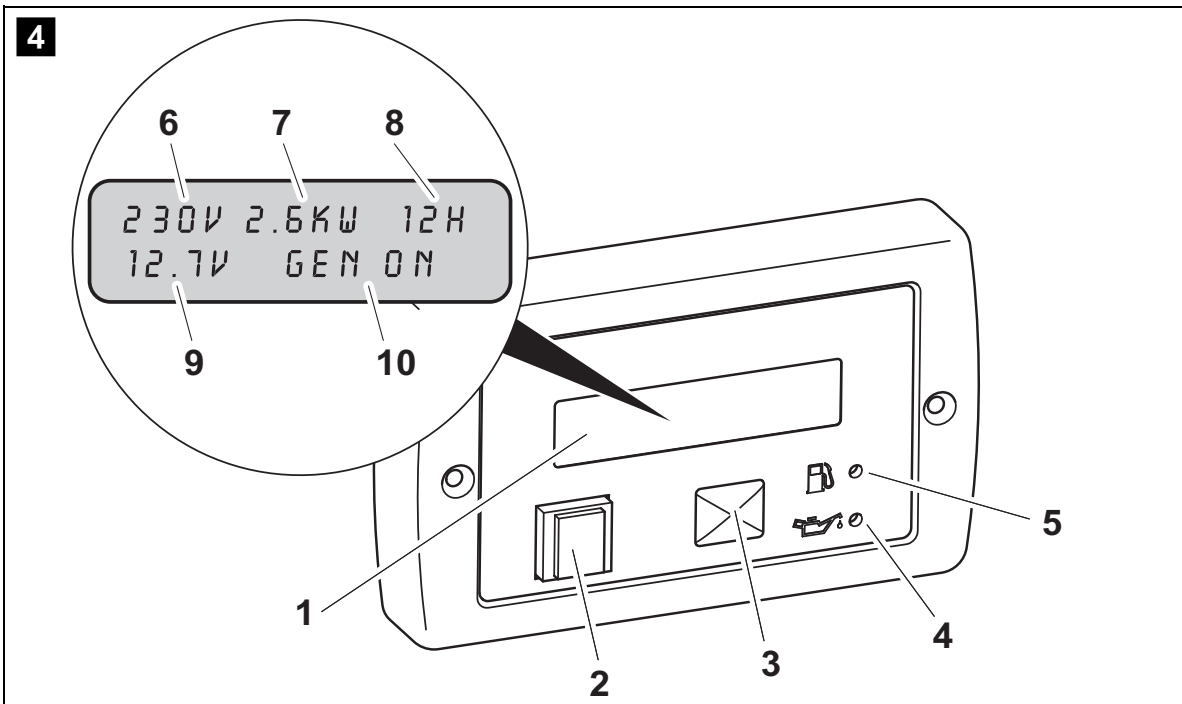
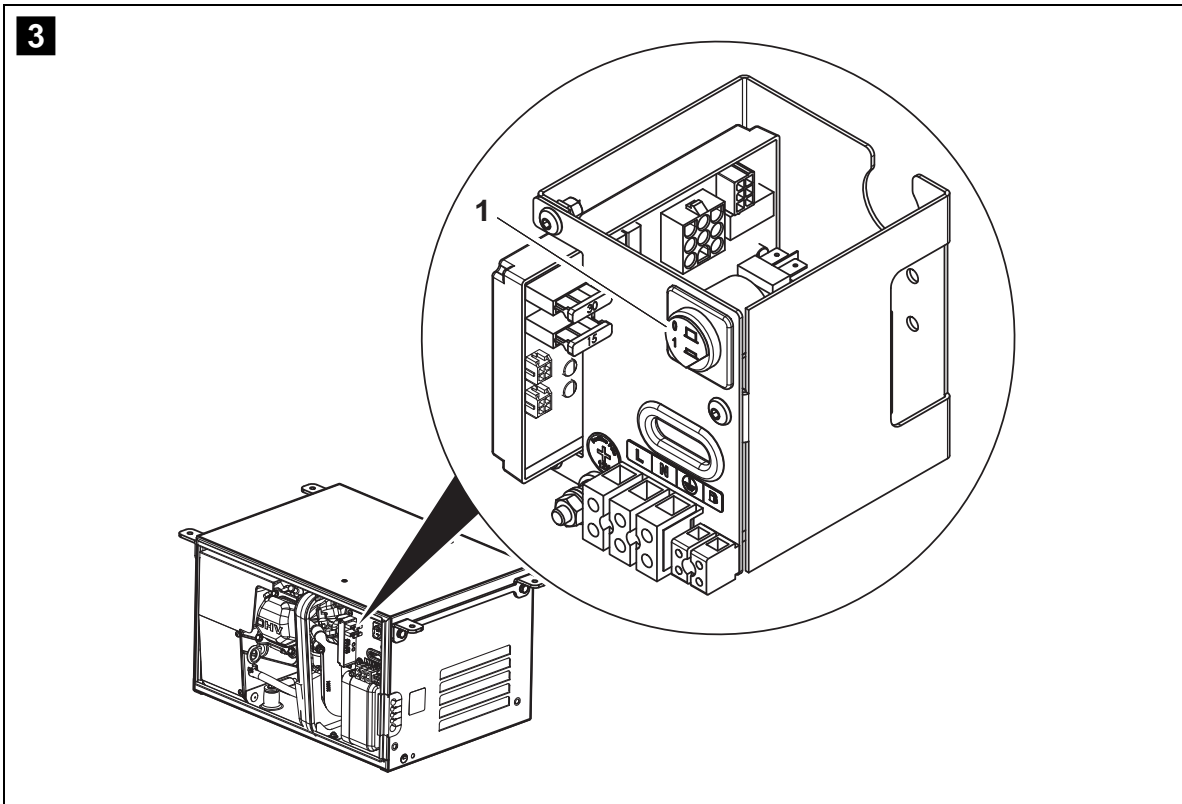

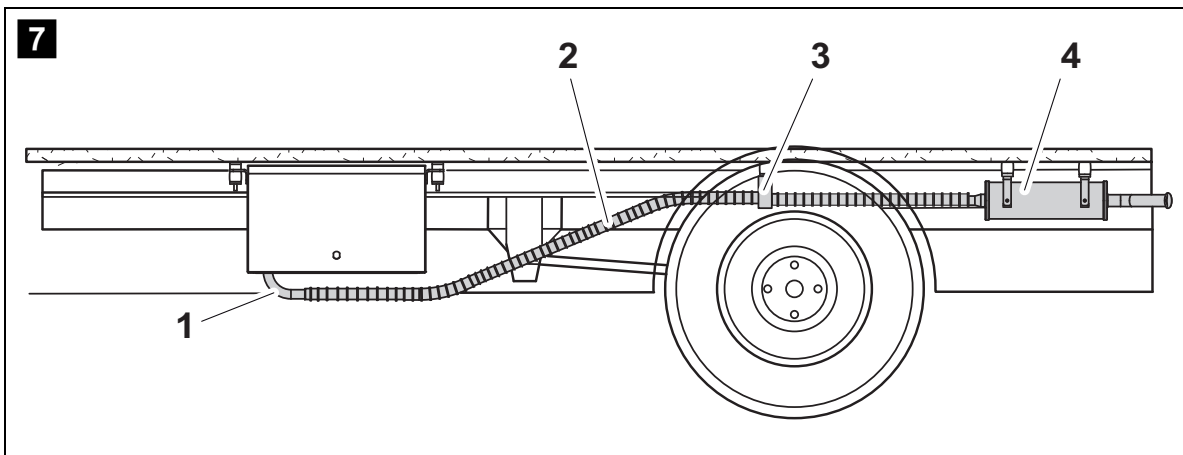
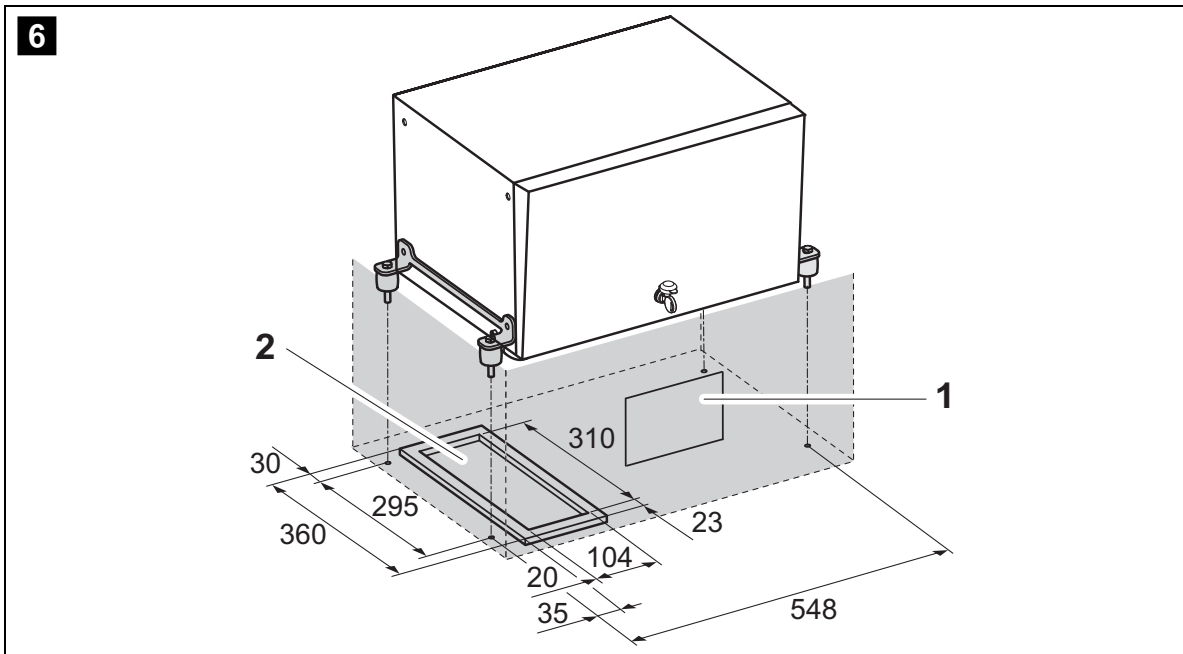
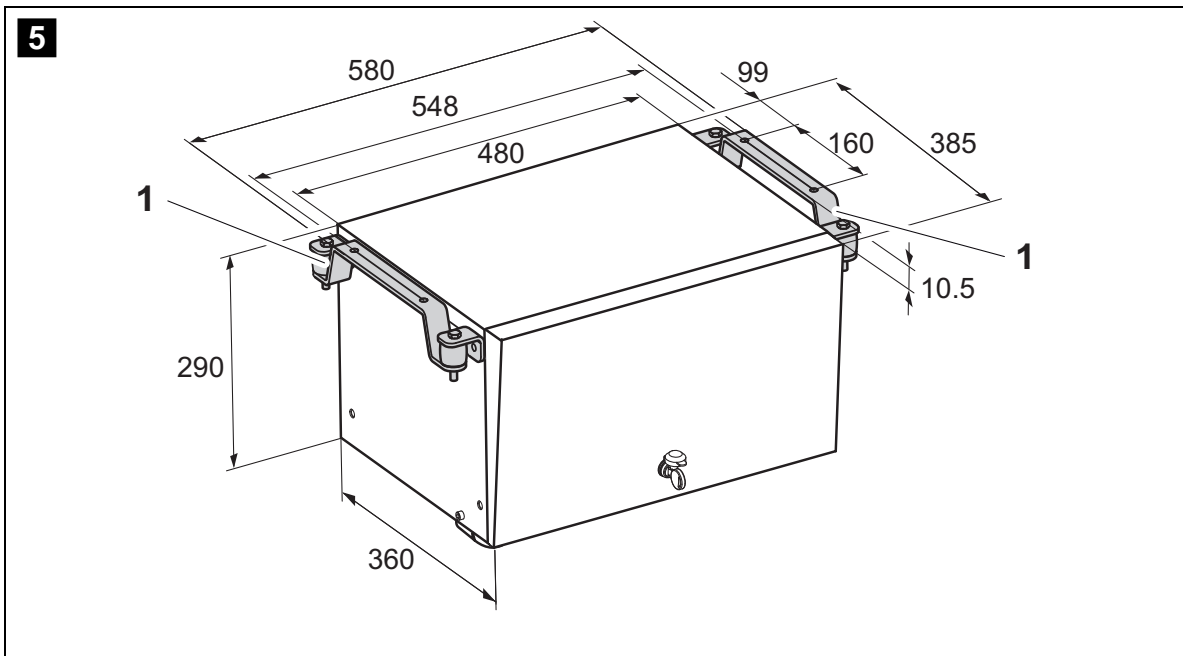

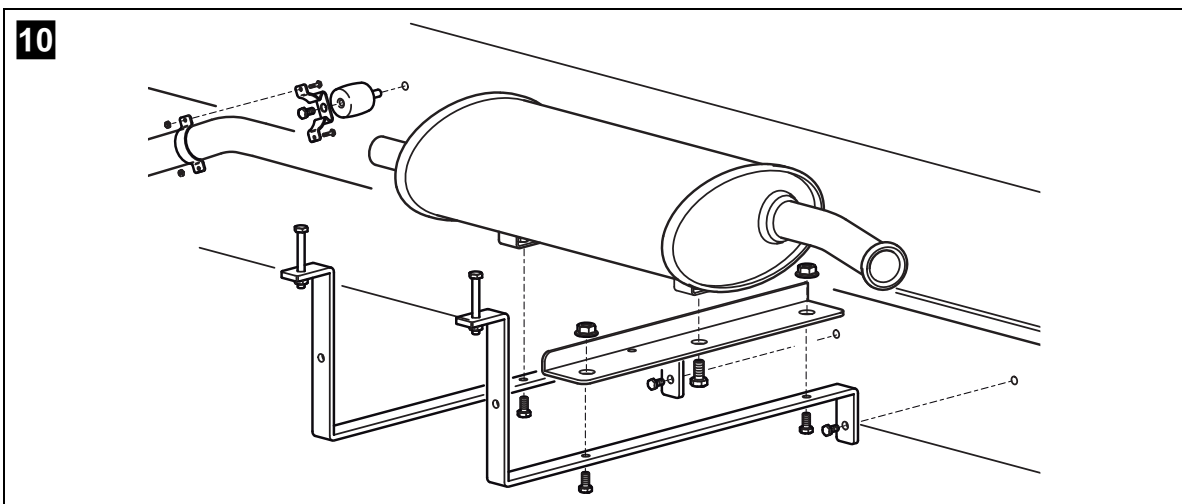
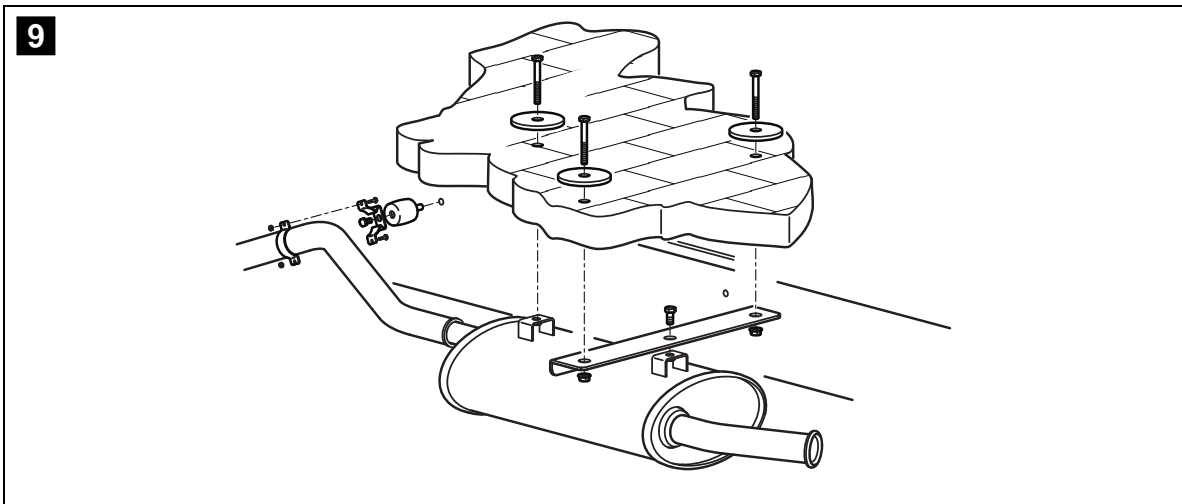
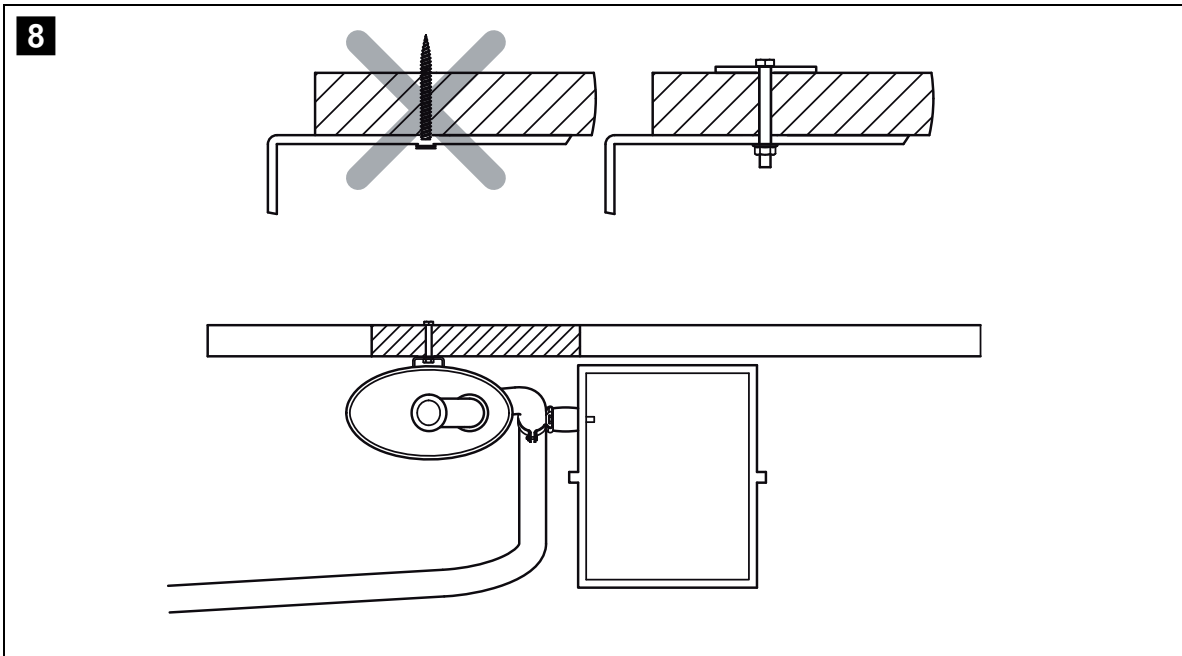

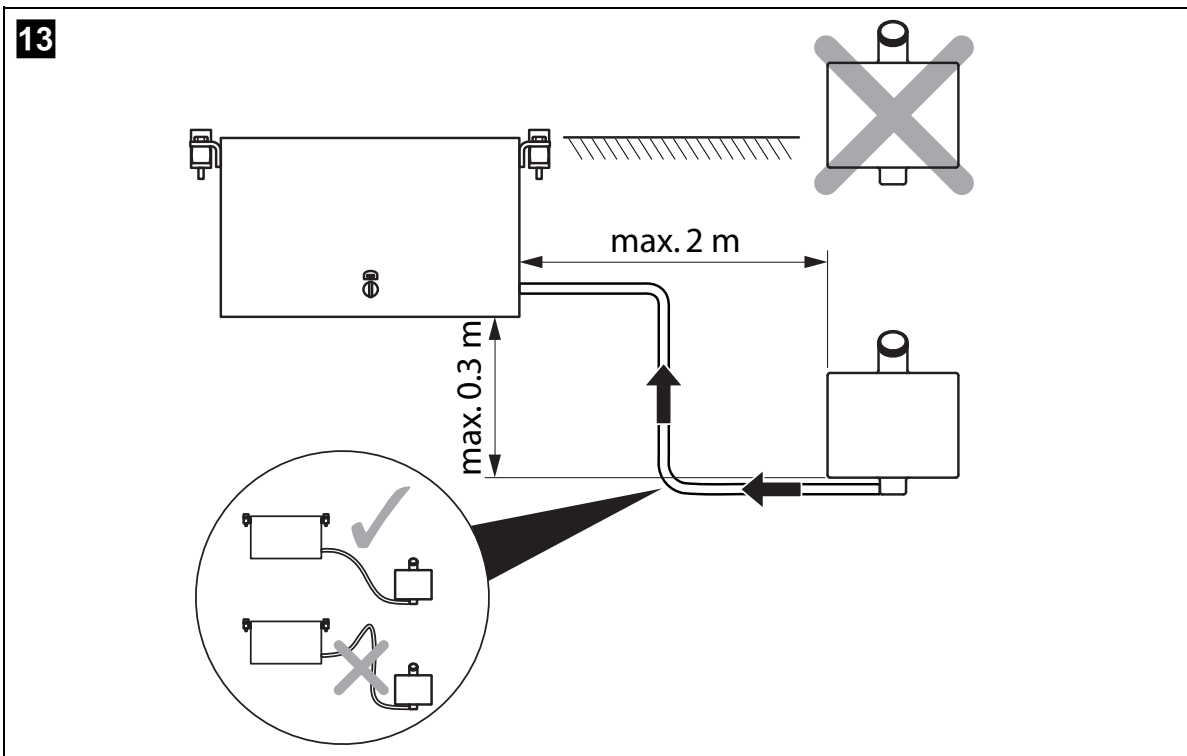
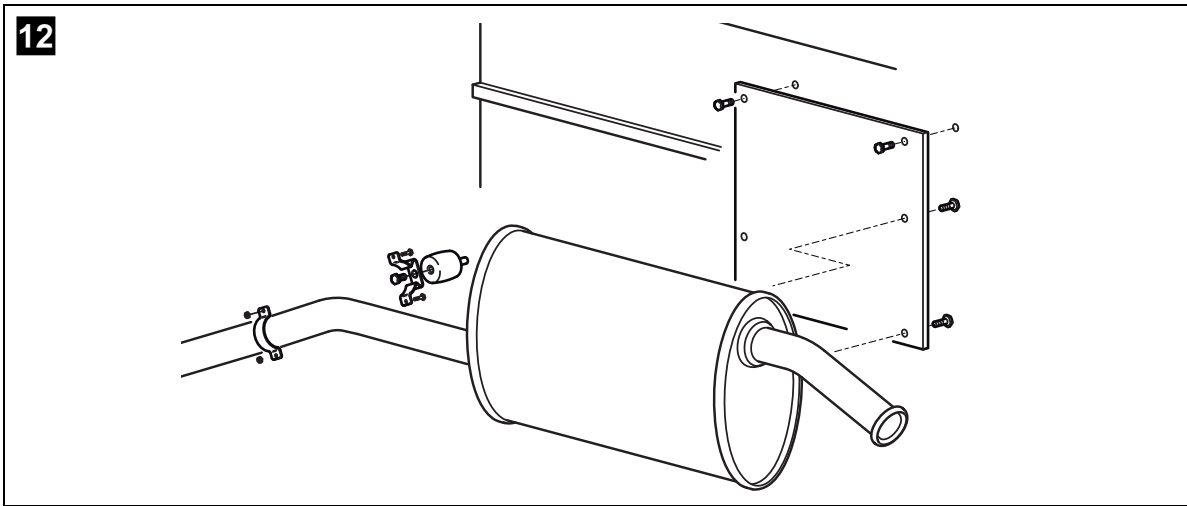
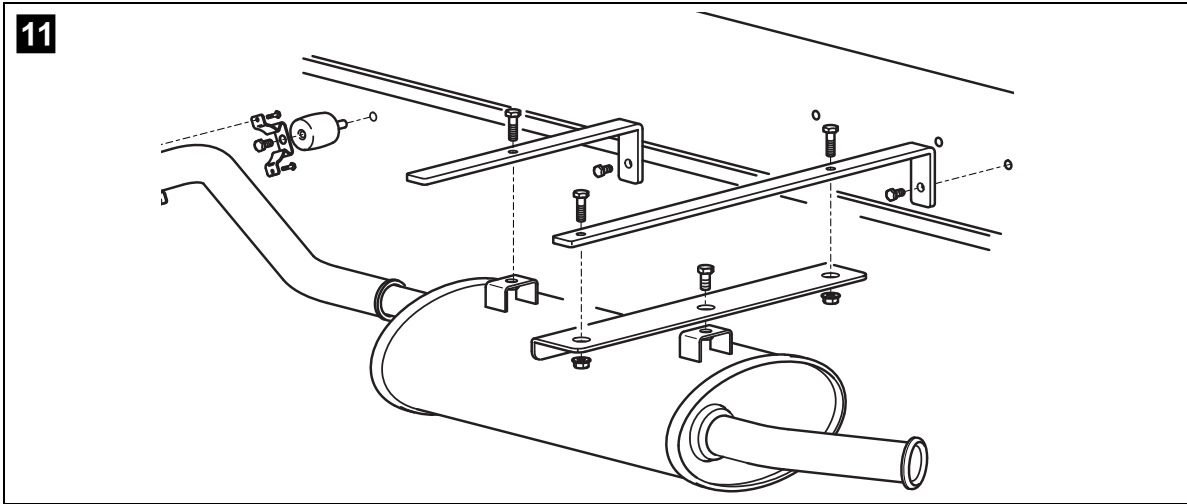

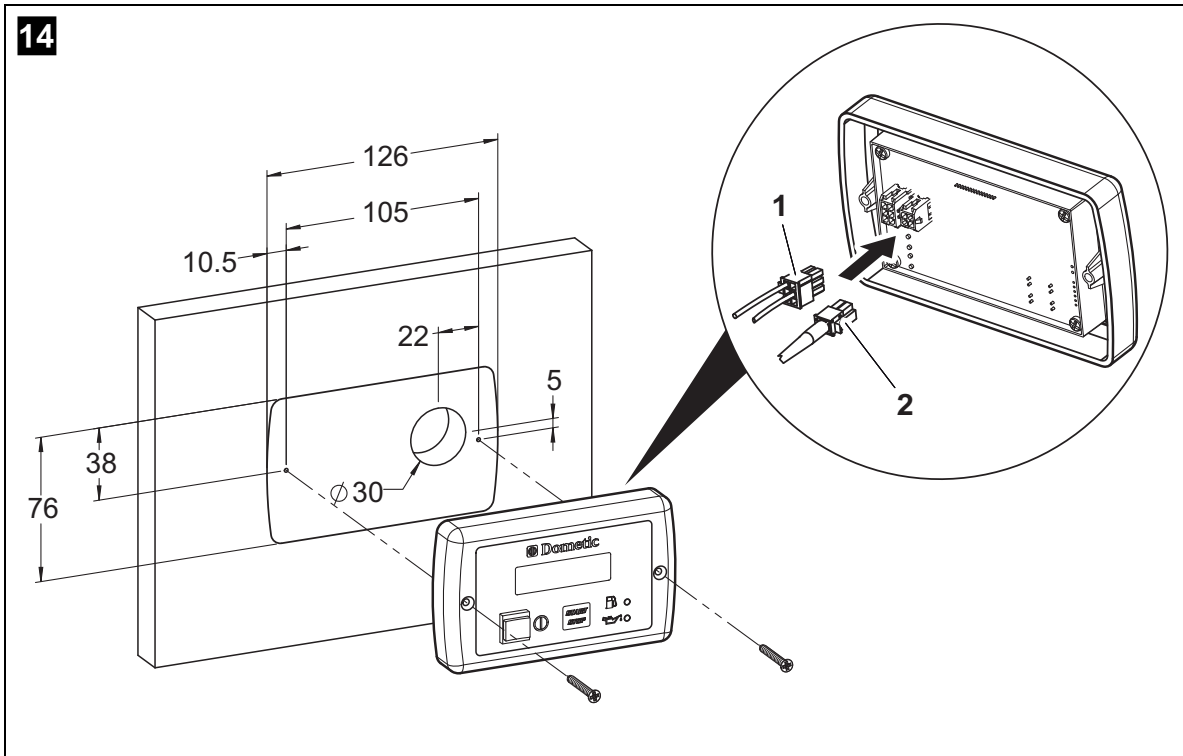

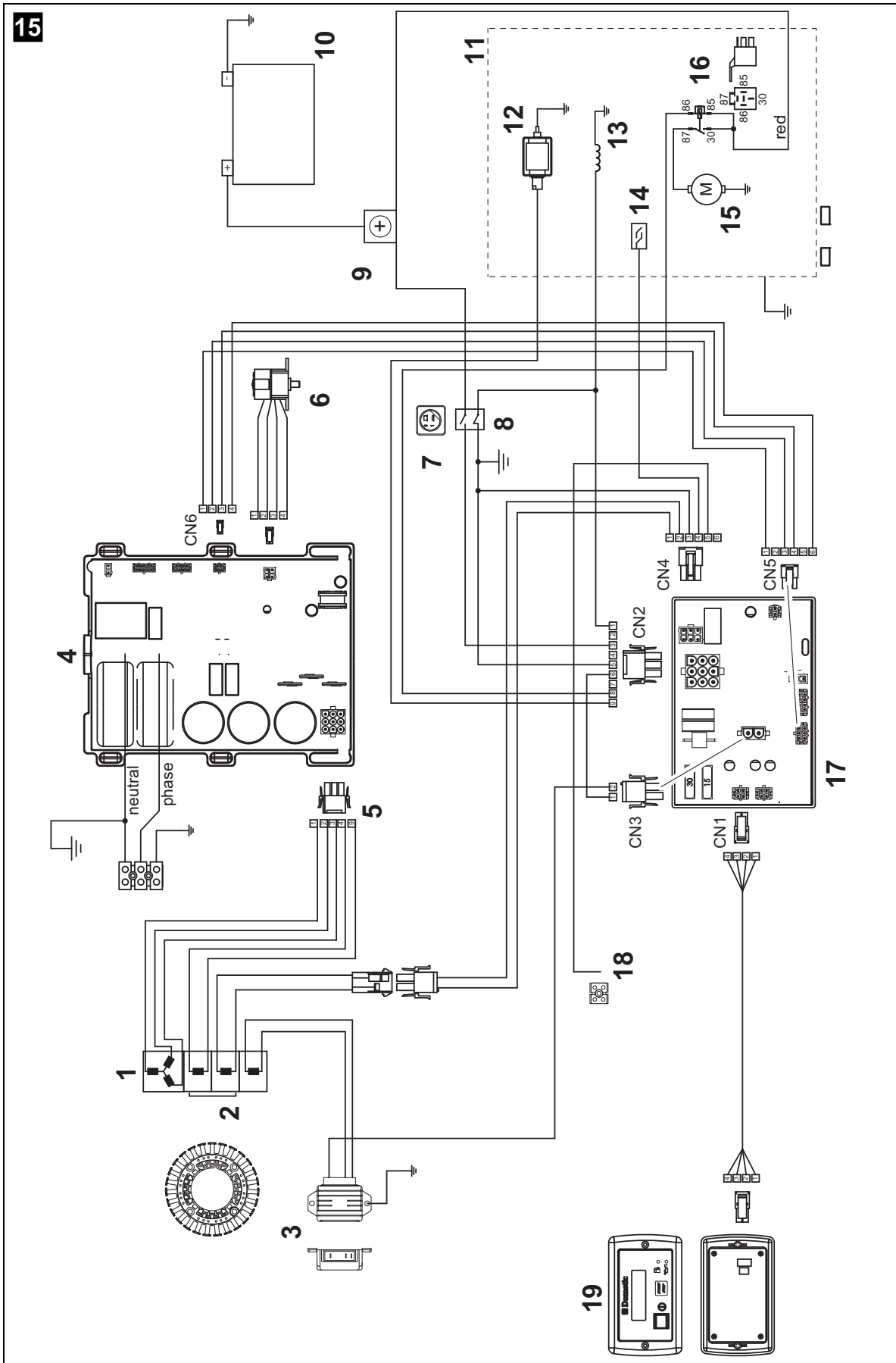

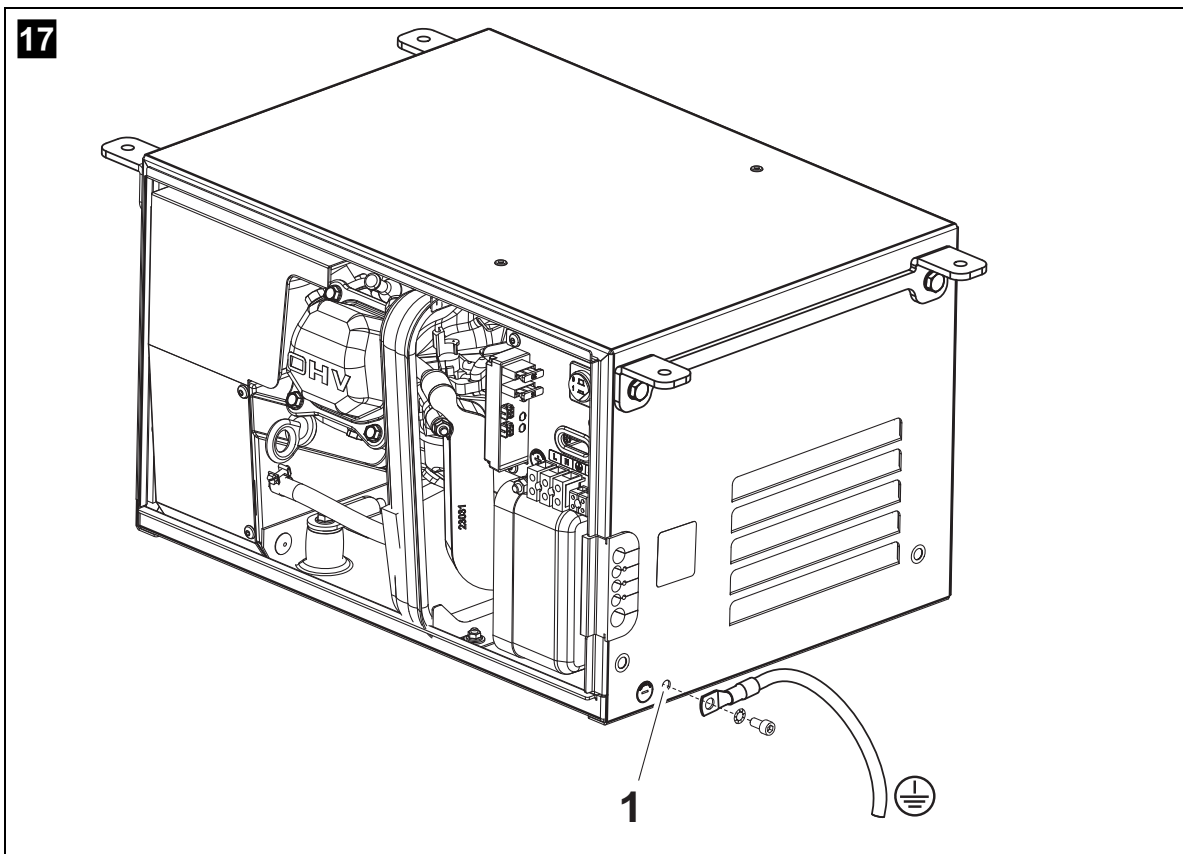
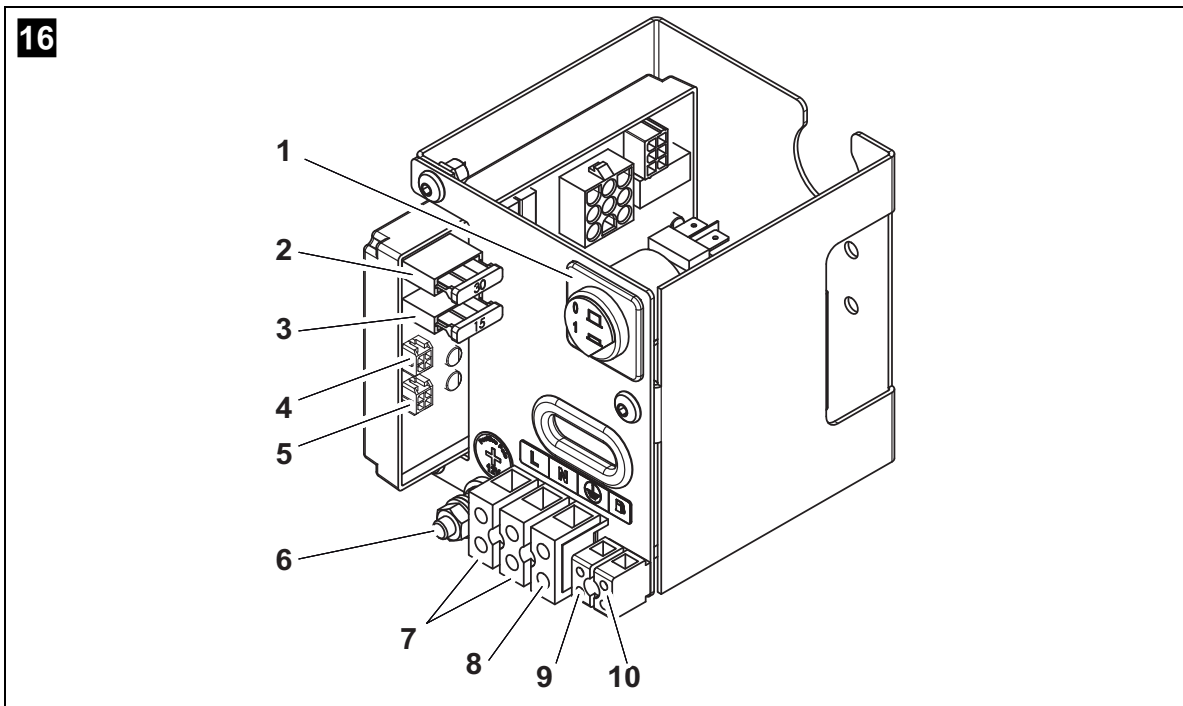

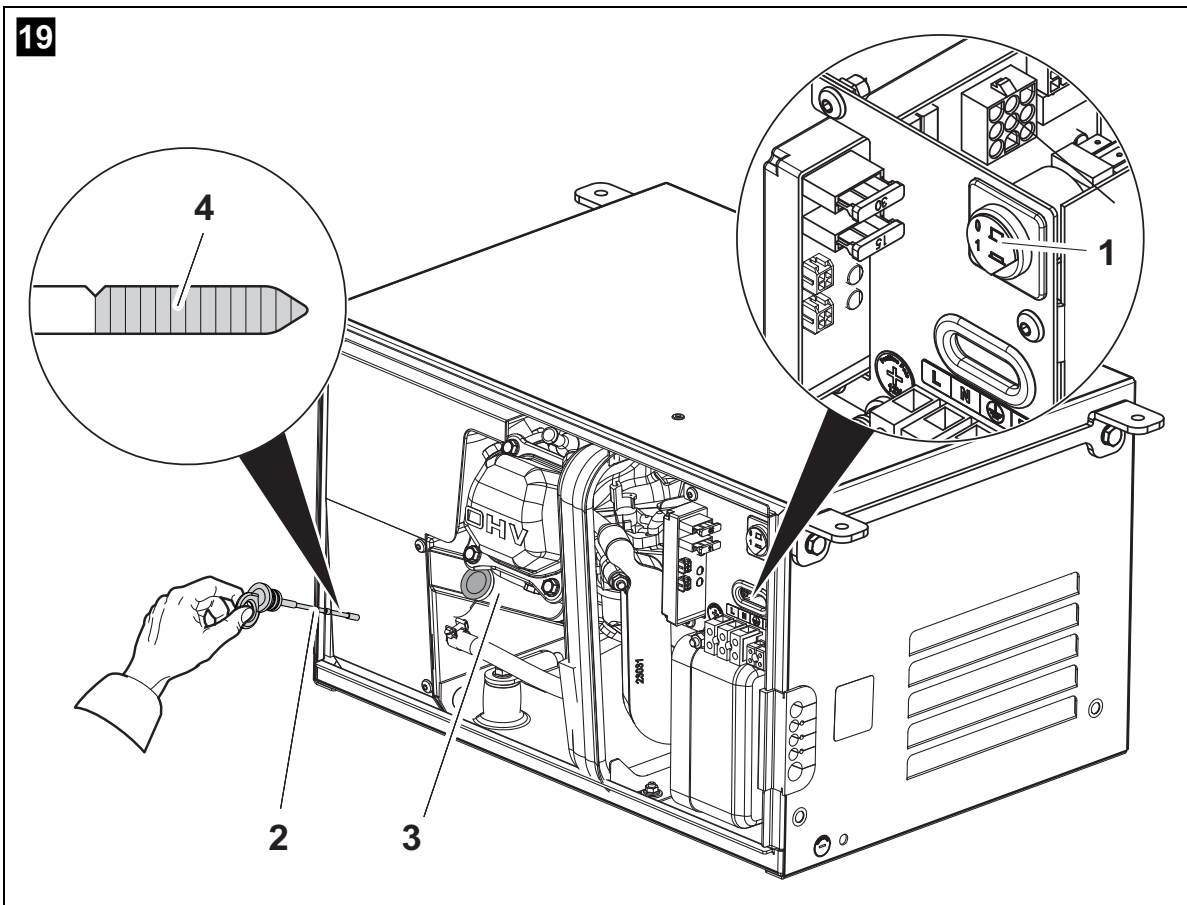
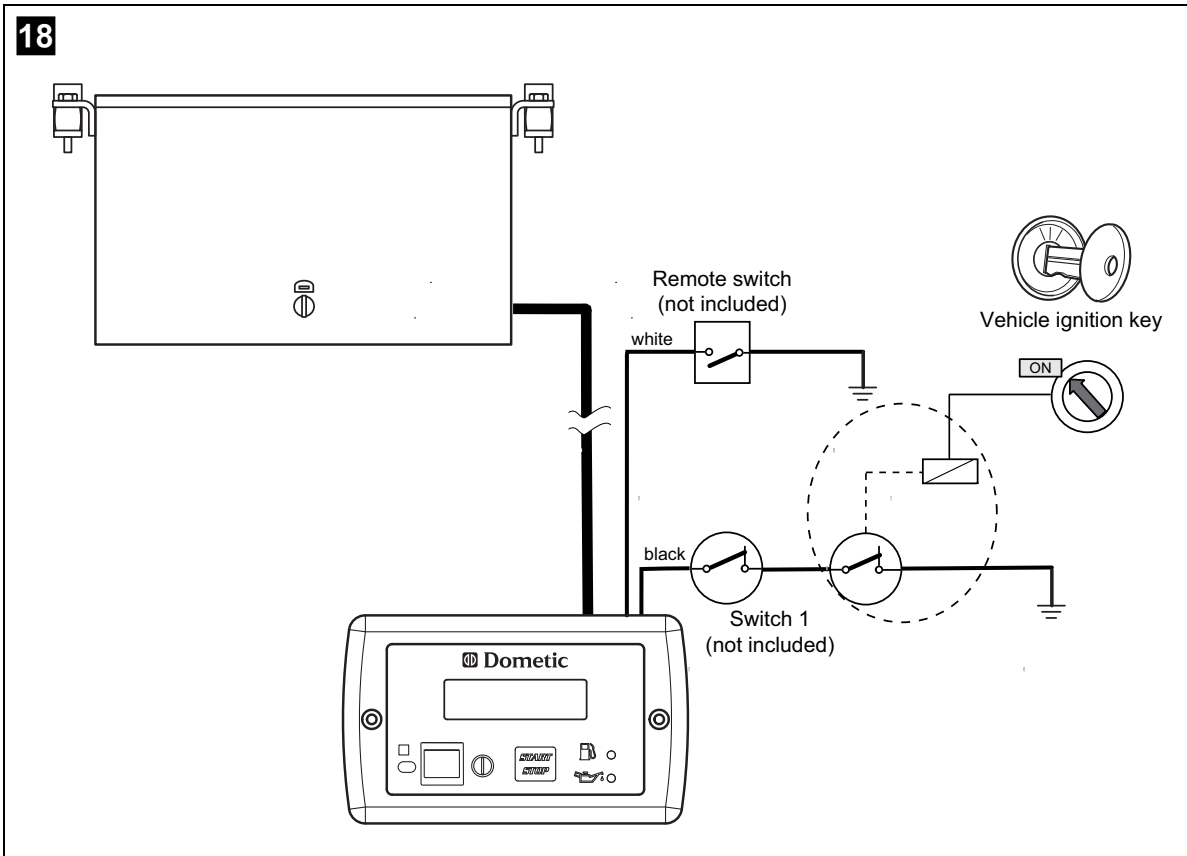

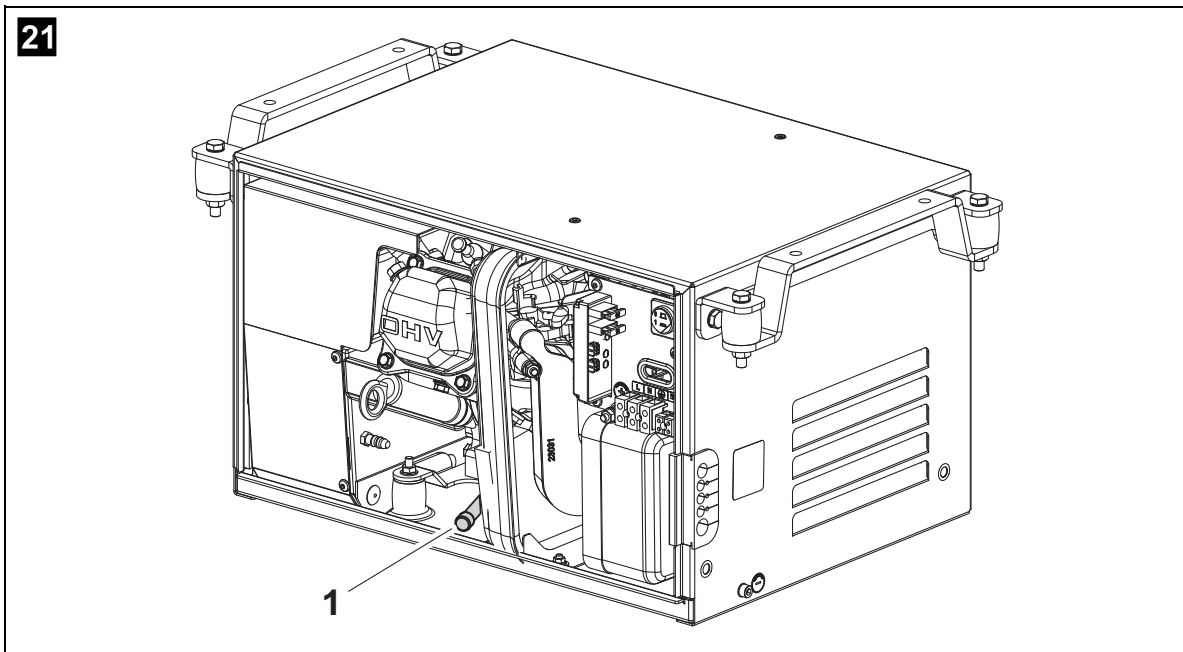
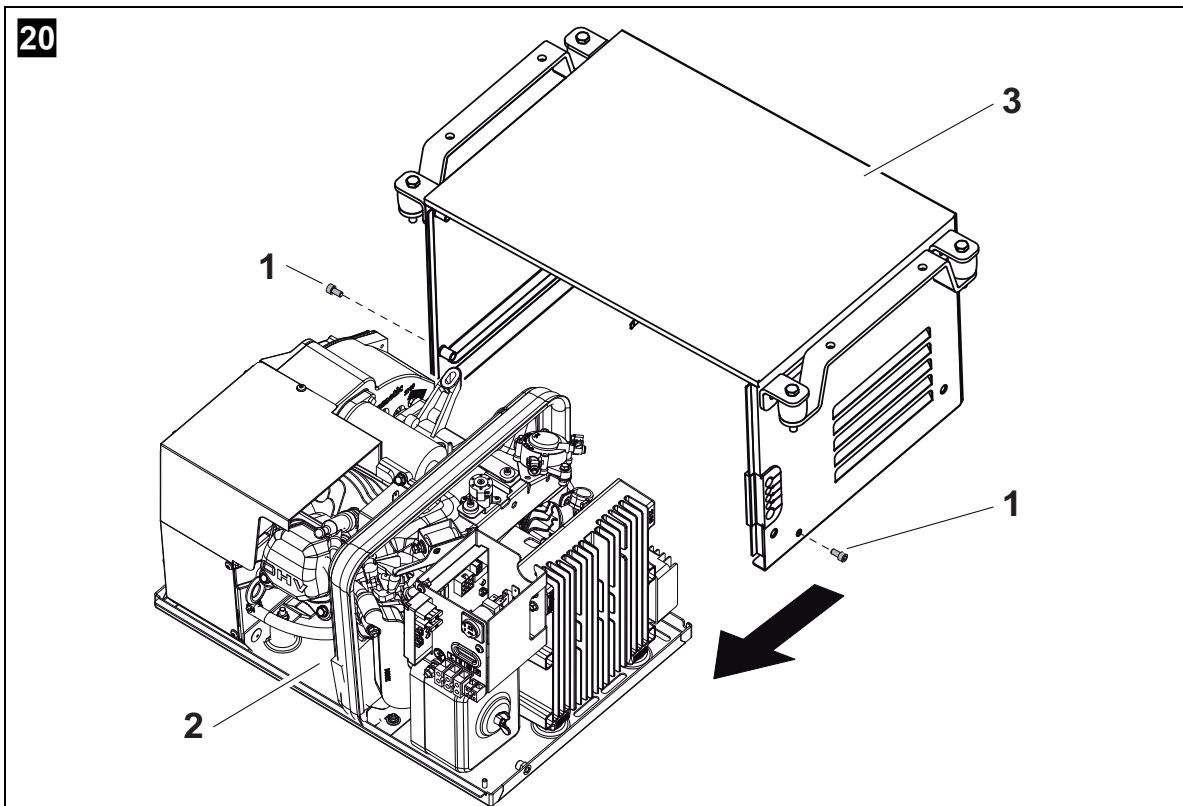

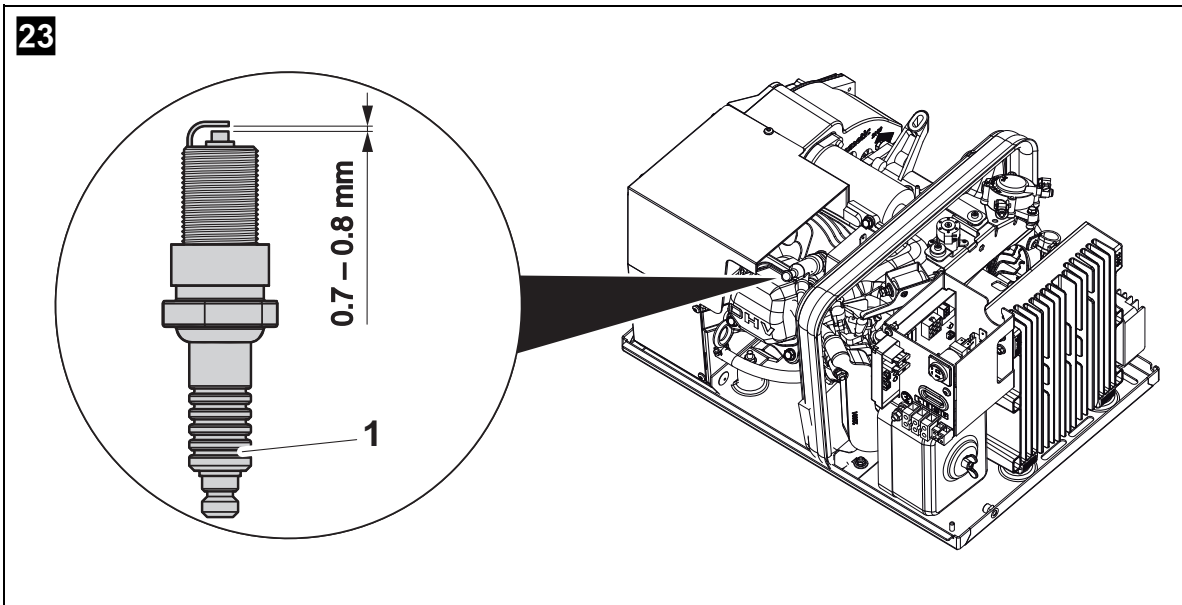
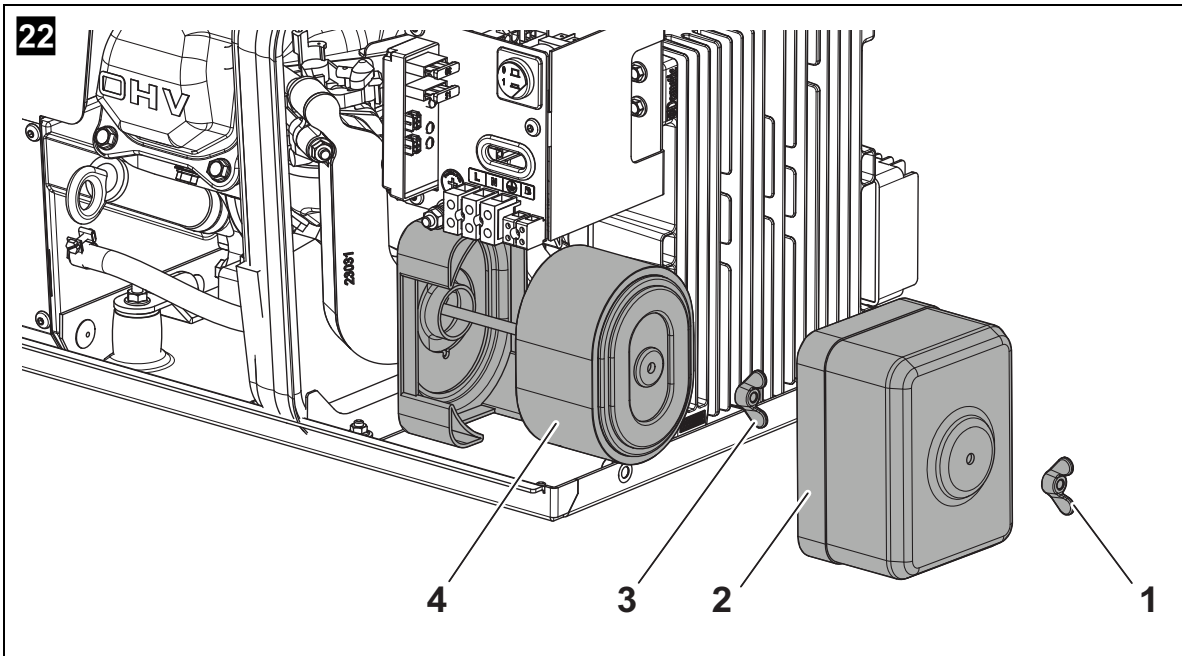

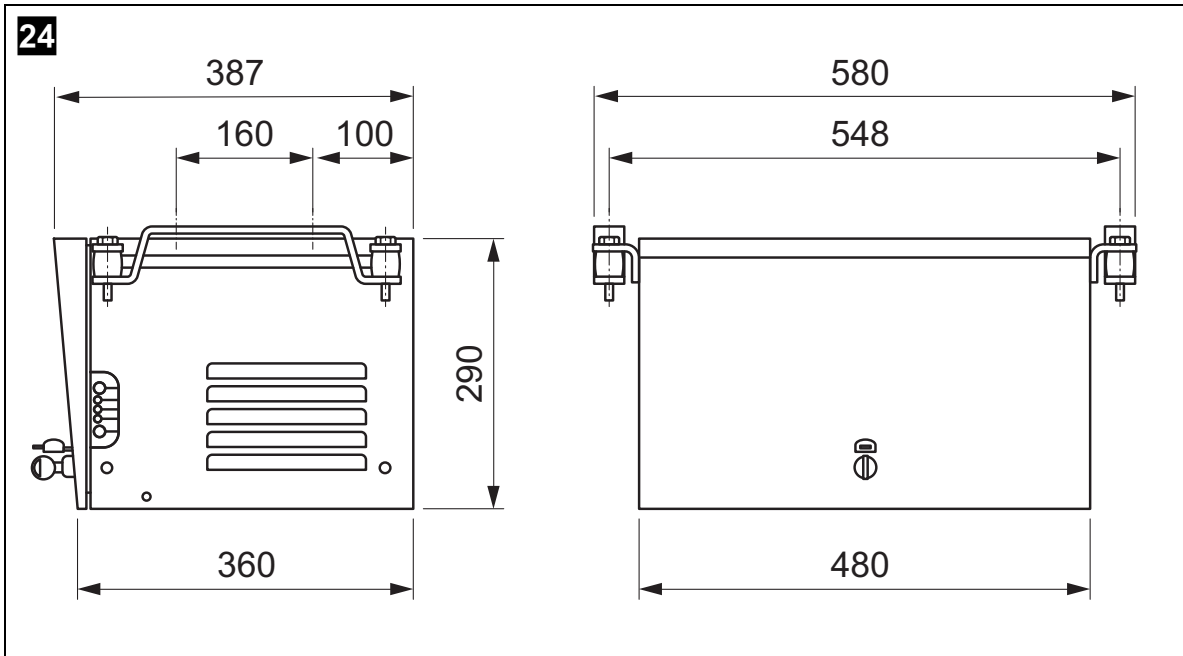

Please read this instruction manual carefully before installation and first use, and store it in a safe place. If you pass on the product to another person, hand over this instruction manual along with it.

Table of contents

1	Explanation of symbols	16
2	Safety instructions	16
3	Scope of delivery	20
4	Accessories	20
5	Intended use	21
6	Labels	21
7	Technical description	22
8	Installation	24
9	Connecting the electrical power to the generator	27
10	Operating the generator	32
11	Cleaning the generator	38
12	Servicing the generator	39
13	Troubleshooting	44
14	Warranty	46
15	Disposal	46
16	Technical data	47

1 Explanation of symbols

**WARNING!**

Safety instruction: Failure to observe this instruction can cause fatal or serious injury.

**CAUTION!**

Safety instruction: Failure to observe this instruction can lead to injury.

**NOTICE!**

Failure to observe this instruction can cause material damage and impair the function of the product.

**NOTE**

Supplementary information for operating the product.

➤ **Action:** This symbol indicates that action is required on your part. The required action is described step-by-step.

✓ This symbol describes the result of an action.

Fig. 1 5, page 3: This refers to an element in an illustration. In this case, item 5 in figure 1 on page 3.

2 Safety instructions

The manufacturer accepts no liability for damage in the following cases:

- Damage to the product resulting from mechanical influences and excess voltage
- Alterations to the product without express permission from the manufacturer
- Use for purposes other than those described in the operating manual

In particular, the manufacturer will not be liable for any consequential damage, especially consequential damage caused by failure of the generator.

Note the following basic safety information when using electrical devices to protect against:

- Electric shock
- Fire hazards
- Injury

2.1 General safety



WARNING!

- **Electrical devices are not toys**
Keep electrical devices out of reach of children or infirm persons. Do not allow them to use electrical devices without supervision.
- People (including children) whose physical, sensory or mental capacities prevent them from using this device safely may not be allowed to operate it without the supervision of a responsible adult.
- Only use the device as intended.
- Do not make any alterations or conversions to the device.
- Installation, maintenance and repairs of the generator may only be carried out by qualified personnel who are familiar with the risks involved when handling generators as well as the relevant regulations. Inadequate repairs may cause serious hazards. For repair service, please contact the manufacturer's branch office in your country (addresses on the back page).
- Exhaust fumes contain carbon monoxide which is a highly toxic, odourless and colourless gas. Do not inhale any exhaust fumes. Do not leave the generator motor running in a closed garage or in a room without windows.



CAUTION!

- The generator may only be used with the front door closed.
- Remove all flammable materials such as petrol, paints, solvents, etc., from the vicinity of the generator.
- Ensure that hot parts of the generator do not come in contact with any flammable materials.
- Only refuel the generator when it is switched off and in a well-ventilated area. Petrol and liquid gas are highly flammable and can explode.

- Do not refuel the generator when the vehicle engine is running if the tank is in the vicinity of the generator.
- If petrol is spilled, wipe it up properly and wait until the fumes have cleared before turning on the engine.
- Do not touch the generator and the cables with wet hands.
- Replace the fuses using only those with the same technical data.
- Do not switch the generator to automatic mode near any ignition sources (such as petrol stations, dry areas with risk of forest fires).

**NOTICE!**

- Do not fill up the tank too full. Petrol must not be allowed to fill up to the neck of the tank. Check the lid is on properly.

2.2 Mounting the device

**CAUTION!**

- **Fire hazards**
Do **not** install the generator in a box or room without any openings, but in well-ventilated spaces instead.
- Install the generator on a stable surface.
- Do not tilt the generator more than 20° from the vertical position.

**NOTICE!**

- The generator is not suitable for use in water vessels.

2.3 Handling electrical cables



WARNING!

- The electrical power supply may only be connected by a qualified electrician.



CAUTION!

- Attach and lay the cables so that they cannot be tripped over or damaged. All the wiring must comply to AS3000 and AS3001.



NOTICE!

- Use cable ducts to lay cables through walls with sharp edges.
- Do not lay loose or bent cables next to electrically conductive materials (metal).
- Do not pull on the cables.

2.4 Operating the device safely



WARNING!

- Always disconnect the power supply when working on the device.



NOTICE!

- Only operate the device if you are certain that the housing and the cables are undamaged.

3 Scope of delivery

No. in fig. 1, page 3	Number	Description
1	1	Generator
2	1	Digital control panel
3	1	Silencer
4	1	Exhaust pipe, 2 m
5	1 set	Mounting bracket for silencer
6	2	Retaining bracket for external installation
7	2	Holder for internal installation
8	4	Spacer
9	1	Extension cable for digital control panel, 8 m
–	8	Washer
–	1	Seal AG 128
–	1	Fuel filter
–	1	Installation and operating manual

4 Accessories

Available as accessories (not included in the scope of delivery):

Part designation	Item number
AG 101, tank 15 l, plastic	9102900009
AG 100, tank 20 l, stainless steel	9102900011
AG 150, pipe set for AG 100/AG 101 (1 m fuel hose refuelling, 60 mm, 2 m fuel hose breathing, 2 m fuel hose feeding)	9102900003
AG 125, flexible metal pipe for extending exhaust pipe, 5 m	9102900138

5 Intended use

The TEC29 EV AUS (item no. 9102900291) generator is designed for use in motor homes, camper vans and vehicles for commercial use.

The generator is not suitable for installation in water vessels.

The generator produces a pure sine wave voltage of 230 V/50 Hz which can be connected to the consumer with a total continuous load of 2600 W. The power quality is also suitable for sensitive consumers (such as PCs).

The generator can charge a 12 V battery (AGM, Gel, lead acid and Dometic eStore Li-Ion battery).

6 Labels

A label is attached to the generator. This label provides the user and fitter with information on the device specifications.

7 Technical description

The TEC29 EV AUS generator consists of the following main parts (fig. **2**, page 3):

- Combustion engine (**1**)
- Alternator (**2**) with permanent magnets
- Stepper motor (**3**)
- Inverter (**4**)
- Internal control panel (**5**)
- Remote control (**6**)

The combustion engine (**1**) drives the alternator (**2**) connected to it, which in turn generates AC voltage.

The inverter (**4**) transforms this AC voltage into a stable voltage of 230 V and 50 Hz.

The terminals, the socket for the connection cable to the digital control panel (**6**) and the main switch are installed in the internal control panel (**5**).

The generator has the following features:

- Automatic mode for charging the connected battery automatically (must be configured accordingly when installed, see chapter “Configuring the automatic mode” on page 31)

Control elements in the control panel

The control panel is located on the generator behind the cover.

No. in fig. 3 , page 4	Description	
1	Main switch	Switches the generator to standby or no function.

Control elements in the digital control panel

The digital control panel is installed in the vehicle interior.

No. in fig. 4, page 4	Description	
1	Display	Shows the status reports.
2	On/Off switch 	Switches the digital control panel on and off if the main switch is at "I" or "1". Stops the generator.
3	START/STOP button	Starts and stops the generator if the digital control panel is switched on and the main switch is at "I" or "1".
4	Oil LED	Lights up if the oil level is too low in the engine.
5	Petrol LED	Lights up if the petrol goes into reserve.

Displays

No. in fig. 4, page 4	Description	
6	AC supply	Approximate voltage ($\pm 5\%$)
7	Power output	Power draw through connected load
8	Operating hours	Time the generator is in operation
9	DC voltage	Battery voltage
10	Messages	Status reports of the generator (see chapter "Display messages" on page 34)

8 Installation



CAUTION! Beware of injury

The generator may only be installed by qualified personnel from a specialist company. The following information is intended for technicians who are familiar with the guidelines and safety precautions to be applied.

8.1 Note on installation

Read the installation manual carefully before you install the generator.

When installing the generator, note the following:



DANGER! Danger of electrocution

Disconnect all power supplies when working on the generator.



CAUTION! Beware of injury

- Improper installation of the generator can result in irreparable damage to the device and put the safety of the user at risk.
- Always wear the recommended protective clothing (e.g. protective goggles, gloves).

8.2 Securing the generator

Note on installation location

- Make sure that no combustible objects are stored or installed near the air outlet or the ventilation slots. A distance of at least 50 cm should be kept.
- For safety reasons, note the location of existing wiring harnesses, wires and other components within the installation area, in particular those which are not visible, when installing the generator (when drilling or screwing etc.).

You can secure the generator with the holders supplied in two ways:

- External installation (fig. **5**, page 5):
External installation has the following benefits: lower space requirement, fast installation, easy access for maintenance work.
 - To ensure the generator is attached securely, use the retaining bracket (fig. **5** 1, page 5) supplied.
 - If the air intake opening of the generator is located behind a vehicle wheel, you need to prevent the wheel from splashing any water into the generator interior when it rains (e.g. by using a splash guard).
- Internal installation (fig. **6**, page 5):
For internal installation, you need to prepare a sealed compartment against the vehicle interior which can also be insulated against sound.
 - Attach exhaust and air intake openings to the floor and in front of the generator cover. The air intake openings must have cross-section of at least 240 cm².
 - You must also fit a seal (AG 128; included in the scope of delivery) made of fire-retardant rubber with a thickness of at least 5 mm between the floor of the vehicle and the generator.
 - Fix the provided 8 washers between the floor and the vibration dampers (2 pieces each).
- Leave a space of at least 20 mm between the generator hood and surrounding parts so that sufficient space remains for cooling air to pass through.

8.3 Securing the silencer

Observe the following instructions when installing the exhaust pipe:

- Do not create any sharp bends which will inhibit the flow of exhaust fumes.
 - Align the manifold (fig. **7** 1, page 5) along the housing to ensure greater damping of vibration.
 - Use the exhaust pipe extension to extend the exhaust pipe (fig. **7** 2, page 5) (see chapter “Accessories” on page 20).
Secure the extension to the vehicle floor (fig. **7** 3, page 5) according to ADR 42.8.
 - If cutting the exhaust pipe, wear protective gloves and be careful of sharp edges.
- Secure the silencer (fig. **7** 4, page 5) as in one of the alternatives shown in fig. **8**, page 6 to fig. **12**, page 7.

8.4 Installing the tank and fuel supply line

Please observe the following instructions for the installation location:

- The tank bottom must be positioned at a maximum of 0.3 m below the bottom of the generator.
 - The top of the tank must not be higher than the top of the generator.
-
- Lay the fuel line as straight as possible.
 - Secure the tank, see fig. **13**, page 7 and chapter “Connecting the float” on page 31.

8.5 Mounting the digital control panel

Please observe the following instructions for the installation location:

- Observe the length of the extension cable from the digital control panel to the generator.
-
- Drill the holes as shown in fig. **14**, page 8.
 - Insert the plug into the digital control panel.
 - Screw on the digital control panel.

9 Connecting the electrical power to the generator

**DANGER! Danger of electrocution**

Make sure there is no voltage at electrically operated components before carrying out work on them!

**NOTICE!**

Protect the system with an RCD breaker according to AS3001 regulation.

**NOTE**

Observe the applicable guidelines in the country of the consumer.

9.1 Important notes on the electrical connection

- Only a qualified electrician should connect the generator to the electrical power.
- Check that the voltage specification on the type plate is the same as that of the power supply.
- Do not lay the 230 V~ mains cable and the 12 V== cable together in the same cable duct.
- Do not lay cables which are loose or bent next to electrically conductive material (metal).
- Connect the generator to a power circuit which can supply the necessary current (see chapter “Technical data” on page 47).
- Select the cross-section of the cable as follows:
 - 230 V: 2.5 mm²
 - Battery connection (length < 6 m): 10 mm²
 - Battery connection (length > 6 m): 16 mm²
- Install a manual main switch which can disconnect all the consumers from the generator with the exception of the battery.

9.2 Circuit diagrams

The complete circuit diagram can be found in fig. **15**, page 9.

Item	Description
1	3-phase winding
2	Auxiliary winding
3	Battery charger
4	Inverter
5	Generator connector
6	Stepper motor
7	Main switch
8	Thermal disconnecter
9	Battery positive terminal
10	Battery
11	Interface module
12	Electromagnet for cold start
13	Motor coil
14	Oil level gauge
15	Starter motor
16	Starter relay
17	Internal control panel
18	4-pin plug
19	Digital control panel

Control panel (fig. 16, page 10)

Item	Description
1	Main switch
2	Main fuse
3	Battery charger fuse
4	Digital control panel connection
5	Connector for service purposes
6	Battery positive terminal
7	230 V connection
8	Earth
9	Float connection (petrol tank)
10	No connection required

9.3 Connecting 230 V**NOTICE!**

- Connect a relay or a change over switch to the vehicle's electrical system so that the generator is not damaged when the external mains is connected (according to AS3001 regulation).
- The neutral conductor is internally linked to the PE conductor. To protect against automatic shutdown, make sure that a safety switch (RCD switch, 30 mA) and an in all-pole overcurrent protection (e.g. circuit breaker, 12 A) are installed (according to AS3001 regulation) between the generator and the change over switch.

- Guide the 230 V connection cable through the cable passage in the housing and connect it to the 230 V terminals (fig. 16 7, page 10).
- Connect the earth cable to the earth connection on (fig. 16 8, page 10).

9.4 Connecting the starter battery

**NOTICE!**

The starter battery must have 12 V and a capacity of at least 60 Ah. Make sure that the battery is fully charged.

- Connect the positive terminal of the battery to the positive battery terminal connection using a cable with a cross-section of 10 mm² for a length of < 6 m or 16 mm² for a length of > 6 m (fig. **16** 6, page 10).
- Fit a 100 A fuse in the positive cable near the positive terminal of the starter battery to protect the generator's electrical system.
- Connect the negative terminal of the battery using a cable with a suitable cross-section (see above) via the insert of the generator (fig. **17** 1, page 10).
- Connect the earth connection on the generator to the vehicle chassis. Remove any paint or rust from the chassis if necessary to ensure good contact.
- Protect the connections by applying lubrication.

9.5 Configuring the automatic mode



NOTE

- You can only use automatic mode:
 - if the vehicle is stationary and the ignition is switched off
- To shorten charging times, an additional charging unit with at least 20 A can be installed between the generator and disconnector switch, especially if batteries with a capacity of more than 60 Ah are used. In this case remove the fuse (fig. **16** 3, page 10) from the internal control panel.

In automatic mode, the generator switches on automatically and charges the battery if the voltage of the connected battery is too low.

The generator switches off automatically once the battery has been fully charged.

The circuit diagram for the automatic mode can be found in fig. **18**, page 11.

- Connect the black wire to a suitable switch and connect the switch to the ignition.
- Connect the white wire to a suitable switch.

9.6 Connecting the digital control panel

- Connect the provided extension cable to the digital control panel (fig. **14** 2, page 8) and the generator control panel (fig. **16** 4, page 10).

Connecting the autostart wiring

- Connect the provided wiring to the digital control panel (fig. **14** 1, page 8).
- To enable the autostart function, connect the black wiring as shown in fig. **18**, page 11.
- To enable the remote ON/OFF function, connect the white wiring as described in fig. **18**, page 11.

9.7 Connecting the float

- Connect the float from the tank to the float connection (fig. **16** 9, page 10).

10 Operating the generator

**NOTICE!**

Do not run the generator over 70 % of the maximum constant output for the first 50 operating hours (run-in phase).

**NOTE**

Run the generator at a maximum of approx. 75 % of the maximum continuous load after the run-in phase.

By doing this you can prolong the service life of the generator and maximise its efficiency.

10.1 Basic notes on operation

**CAUTION! Beware of injury**

Do not insert your fingers or objects into the air nozzles or the intake grille.

Please note the following basic information:

- Always check the oil level before use (chapter “Checking the oil level” on page 36).
- Leave the generator running for a few minutes after use without any consumers before stopping it.
- If you are not using your generator for a longer period of time, start it up at least every 30 days and leave it running for 15 minutes or more.

10.2 Switching the generator to standby or no function

The generator can be switched to standby or no function with the main switch (fig. **3** 1, page 4) in the control panel.

10.3 Switching the digital control panel on and off

This switch (fig. **4** 2, page 4) on the digital control panel is for switching the digital control panel on and off.

- Switch the digital control panel on with the on/off switch.
- ✓ The display shows: *GEN OFF*.
The display switches off automatically after 5 minutes if the start button is not touched within this time.
Press and hold the start button for 4 s to switch on the display again.
- ✓ The generator can now be started.

10.4 Starting the generator

The generator can only be started if it is in standby and the digital control panel is switched on.

- Start up the generator by pressing the start/stop button (fig. **4** 3, page 4).

10.5 Stopping the generator

- Stop the generator by pressing the start/stop button (fig. **4** 3, page 4).
If the generator does not stop: switch it off by pressing the red on/off button or by pressing the main switch (fig. **3** 1, page 4) on the internal control panel.

10.6 Display messages

To reset the digital control panel when a message appears, press the on/off switch.

Display message Description	Generator behaviour	Measures
<i>LOW BATTERY</i> The battery voltage has fallen below the minimum value for starting up (9V).	The generator does not start.	Charge the battery.
<i>OIL CHANGE</i> The number of prescribed operating hours has been reached for changing the engine oil.	The generator continues to run.	Change the oil (see chapter "Changing the oil" on page 41), then restart the generator by pressing and holding down the start button.
<i>FUEL LOW</i> The fuel in the tank is in reserve.	The generator continues to run.	Refuel.
<i>OIL ALERT</i> Insufficient engine oil.	The generator stops.	Fill up with oil (see chapter "Checking the oil level" on page 36).
<i>GENERATOR ALERT!</i> General alarm message Example: The control ring on the throttle valve of the carburettor (stepper motor) is faulty.	The generator stops.	Check the system by referring to the troubleshooting table. If the problem persists, contact the manufacturer's branch office in your country (addresses on the back page).
<i>OVERLOAD!</i> The consumers generate an overload at the output.	The inverter switches off, therefore no voltage is supplied but the engine carries on running until it goes off.	Reduce the connected load and start the generator again.
<i>SHORT CIRCUIT</i> The consumers cause a short circuit at the output.	The inverter switches off, therefore no voltage is supplied but the engine carries on running until it goes off.	Check the connected consumers then start the generator again.
<i>OVER TEMPERATURE</i> Overheating	The inverter switches off so no voltage is supplied to cool the generator, but the engine carries on running.	Leave the engine to cool down for a few minutes then start the generator again.

Display message Description	Generator behaviour	Measures
<i>GEN CAL</i> Message appears when the generator is started up; it shows the calibration phase which takes place before each start-up. The generator does not supply any voltage.	The generator is running but does not supply any voltage.	Wait a moment.
<i>GEN WRIT</i> Message appears while you are waiting for the generator to start again.	The generator is switched off.	Wait until the message has disappeared then attempt ignition again.
<i>GEN ON</i> The generator is operating normally.	Normal mode	–
<i>GEN OFF</i>	The generator is in stand-by and can be started.	–
<i>ENABLE AUTOSTART (HOLD) CONFIRM</i> Message appears when the automatic mode is switched on.	Controls are waiting for user input	Press the start button within 15 seconds and hold down for 4 seconds.
<i>GEN AUTO</i> Automatic mode	The automatic mode is switched on	–
<i>COOLING</i>	The generator keeps on running but the inverter is off.	Wait until the unit cools down; the generator will automatically turn off.

10.7 Checking the oil level

**CAUTION!**

Hot oil can cause burns.
Only check the oil level when the generator is switched off.

**NOTE**

The generator must be level.

Always check the oil level before use. To do this, proceed as follows (fig. **19**, page 11):

- Open the generator front door.
- Switch the generator to no function with the main switch **(1)**.
- Disconnect the positive terminal of the supply battery.
- Take the dipstick **(2)** out of the filler neck **(3)**.
- Clean the dipstick **(2)** with a cloth.
- Put the dipstick **(2)** back into the filler neck **(3)**.
- Take the dipstick **(2)** out of the filler neck.
- Check that the oil level is between the notch (maximum filling level) and the tip of the dipstick **(4)**.
If not, top up with more oil.
- Put the dipstick **(2)** back into the filler neck **(3)**.
- Connect the generator to the positive terminal of the supply battery.
- Switch the generator to standby with the main switch **(1)**.
- Close the generator front door.

10.8 Switching to automatic mode

You can only switch to automatic mode:

- if it was configured when the generator was installed (see chapter “Connecting the autostart wiring” on page 31)
- if the vehicle is stationary and the ignition is switched off

In automatic mode, the generator switches on automatically and charges the battery if the voltage of the connected battery is too low.

The generator switches off automatically once the battery has been fully charged.

The generator can also be turned ON/OFF using a remote switch (not provided) as indicated in fig. **18**, page 11.

To switch on the automatic mode:

- Switch on the automatic mode switch (if available).
- Switch the ignition off.
- Switch the digital control panel on by pressing the on/off switch.
- ✓ The display shows: *ENABLE AUTOSTART (HOLD) CONFIRM*



NOTE

If *GEN OFF* appears on the display instead of *ENABLE AUTOSTART (HOLD) CONFIRM*, the automatic mode is not configured for your generator. If this is the case, contact the specialist workshop which installed the generator and have the automatic mode retrofitted.

- Press the start button within 15 seconds and hold it down for 4 seconds.
- ✓ The display shows: *GEN AUTO*.
- The automatic mode is switched on.

10.9 Switching off the automatic mode

- Switch off the automatic mode switch (if available).

or

- Switch on the ignition.
- ✓ The display shows: *GEN OFF*.

11 Cleaning the generator



NOTICE! Beware of damage

- Do not clean the generator with a high-pressure cleaner. Exposure to water can damage the generator.
- Do not use sharp or hard objects or cleaning agents for cleaning as these may damage the generator.
- To clean the generator, use water with a gentle cleaning agent. Never use petrol, diesel or solvents.

- Clean the generator with a damp cloth from time to time.
- Remove any dirt from the air vents in the generator at regular intervals. Make sure you do not damage the grilles of the generator in the process.

12 Servicing the generator

12.1 Maintenance table



WARNING!

Only have maintenance work carried out by specialist personnel who are familiar with the relevant regulations. Inadequate maintenance may cause serious hazards.



NOTE

Have the following maintenance work performed at regular intervals or after the specified number of operating hours, whichever is sooner.

Interval	Inspection/maintenance
In the first month or after 20 hours	<ul style="list-style-type: none"> ➤ Change the oil. ➤ Check the air filter (chapter “Servicing the air filter” on page 42).
Every 3 months or after 50 hours	<ul style="list-style-type: none"> ➤ Check the air filter (chapter “Servicing the air filter” on page 42).
Every 6 months or after 100 hours	<ul style="list-style-type: none"> ➤ Change the oil. ➤ Check the spark plug (chapter “Servicing the spark plugs” on page 43).
After 150 hours	<ul style="list-style-type: none"> ➤ Check and clean the spark arrestor.
Once a year or every 300 hours	<ul style="list-style-type: none"> ➤ Check the valves' adjustment. ➤ Check the fuel tank and fuel filter. ➤ Check the vibration damper.
Every two years	<ul style="list-style-type: none"> ➤ Check the petrol supply lines.

12.2 Preparing maintenance work



CAUTION!

Note the following for all maintenance work:

- The generator must not be running.
- All the parts must be cooled down.

- Switch the generator to the off position with the main switch (fig. **19** 1, page 11).
- Disconnect the positive terminal of the supply battery.
- Open the generator front door.

For maintenance work, you can take the generator out (fig. **20**, page 12):



WARNING!

The mounting plate with generator is very heavy (> 40 kg) and could fall out the housing if you take it out too far.

- Undo the fastening screws (**1**).
- Remove the mounting plate (**2**) with the generator from the housing (**3**).

12.3 Finishing maintenance work

- Connect the generator to the positive terminal of the supply battery.
- Switch the generator to standby with the main switch (fig. **19** 1, page 11).
- Close the generator front door.

12.4 Changing the oil

**CAUTION!**

Hot oil can cause burns.

**NOTICE!**

Only dispose of used oil at a specialist recycling station and observe the local laws for environmental protection.

You may use the following oil:

- API SG or SF grade oil for four-stroke engines.
- SAE 10W-30 grade oil (can be used at any temperature).
- Oil with single grade oil viscosity.
Select the appropriate viscosity according to the average temperature on-site.

Change the oil as follows (fig. **21**, page 12):

- Allow the generator to run until warm so that the oil can drain off faster and completely.
- Place a suitable receptacle under the drain plug (1).
- Take out the drain plug (1).
- ✓ The oil drains off.
- Pour fresh oil into the nozzle.
The amount of oil is: 0.6 l.

12.5 Servicing the air filter

**WARNING! Danger of explosions**

Do not use diesel oil or solvents with low boiling points for cleaning the air filter. They could ignite or explode.

**NOTICE!**

Never leave the engine running without an air filter. Otherwise this quickly wears out the engine.

**NOTE**

If the air filter is dirty, the air flow to the carburettor is reduced. Check the filter regularly so that the carburettor can function properly. Check this more frequently if the generator is being used in particularly dusty environments.

Service the oil filter as follows (fig. **22**, page 13):

- Prepare the maintenance work and pull the generator out of the housing slightly: see chapter “Preparing maintenance work” on page 40.
- Remove the butterfly nut (1) and the filter cover (2).
- Remove the butterfly nut (3).
- Take out the air filter (4).
The air filter consists of two parts: a sponge filter and a paper filter.
- Check the condition of both parts of the filter carefully. Replace the damaged filter parts.
- Clean the undamaged filter parts; see the following section.
- Finish the maintenance work, see chapter “Finishing maintenance work” on page 40.

Cleaning the sponge filter

- Wash the sponge with a neutral detergent solution and rinse it thoroughly.
- Leave the sponge to dry completely.
- Soak the sponge in fresh engine oil.
- Squeeze out the excess oil.

Cleaning the paper filter

- Knock the dirt off the paper by banging it lightly on a hard surface or use compressed air to blow through the filter.

Do **not** brush the paper as this will push the dirt into the fibres of the paper filter.

- Change the paper filter if it is heavily soiled.

12.6 Servicing the spark plugs



NOTICE!

- Screw the spark plugs in carefully. A loose spark plug can get very hot and damage the engine.
- Only use the same type of spark plugs.
- When you insert a new spark plug, screw it in by 1/2 a turn once it is firmly on the washer. If you are using used spark plugs, turning them 1/8 or 1/4 is suffice.

- Prepare the maintenance work, see chapter “Preparing maintenance work” on page 40.
- Remove the spark plug connector.
- Remove the spark plug using a spark plug wrench.
- Make a visual inspection of the spark plugs.
Replace the spark plug if it is clearly worn or the isolator is damaged or broken.
If the spark plug is just dirty, clean it with a steel brush.
- Measure the distance between the electrodes with a thickness gauge (fig. 23, page 13). It must be 0.7 – 0.8 mm and can be corrected by bending the electrode if necessary.
- Check whether the spark plug seal is intact.
- If so, screw in the spark plugs by hand to avoid damaging the thread.
- Tighten the spark plugs using a spark plug wrench so that the washer is pressed together.
- Finish the maintenance work, see chapter “Finishing maintenance work” on page 40.

13 Troubleshooting

Fault	Cause	Remedy
The digital control panel does not come on when the on/off switch is pressed.	Starter battery is flat (9 V).	➤ Charge the starter battery.
	Power cable is disconnected or the plug is removed.	➤ Contact an authorised workshop.
	Generator earth cable is disconnected or the fuse (if available) is blown.	
The starter does not work when the start button is pressed.	Starter battery is flat.	➤ Charge the starter battery.
	The main switch is at "0".	➤ Set the main switch to "I" or "1".
	Starter shaft is dirty.	➤ Clean the starter shaft.
	Too much oil in the engine.	➤ Drain the oil.
	Inverter is damaged.	➤ Contact an authorised workshop.
	Power cable is disconnected or the plug is removed. Generator earth cable is disconnected or the fuse (if available) is blown. Starter is not receiving any power.	
The starter turns but the generator does not start.	Not enough fuel in the fuel pipe or fuel tank is empty.	➤ Fill up with petrol.
	Spark plug is not receiving any power.	➤ Check the electric connections.
	Carburettor is not receiving any petrol.	➤ Clean the carburettor.
	Air intake is blocked.	➤ Check the air filter (see chapter "Servicing the air filter" on page 42).
	Inverter is damaged.	➤ Contact an authorised workshop.
	Power cable is disconnected or the plug is removed.	

Fault	Cause	Remedy
The generator tends to stall.	Too much oil in the engine.	➤ Drain the oil.
	Load is over 2.6 kW.	➤ Reduce the consumers.
	Carburettor is not receiving any petrol.	➤ Clean the carburettor.
	Air intake is blocked.	➤ Check the air filter (see chapter "Servicing the air filter" on page 42).
	Inverter is damaged.	➤ Contact an authorised workshop.
	Electromagnet is blocked. Air filter is dirty.	
The generator is running but does not supply any voltage.	Inverter is damaged.	➤ Contact an authorised workshop.
	The stepper motor is faulty or the cable is disconnected.	
	Electromagnet is blocked.	
	The throttle valve is blocked.	
The generator starts up very fast and then the "GENERATOR ALERT" message appears.	Generic alarm	➤ If the problem persists, contact an authorised workshop.
	Inverter is damaged.	➤ Contact an authorised workshop.
	The stepper motor is faulty or the cable is disconnected.	
The generated voltage is unstable.	Inverter is damaged.	➤ Contact an authorised workshop.
	The stepper motor is faulty or the cable is disconnected.	

14 Warranty

The statutory warranty period applies. If the product is defective, please contact the service partner in your country (addresses on the back on the instruction manual).

Our experts will be happy to help you and will discuss the warranty process with you in more detail.

15 Disposal

- Place the packaging material in the appropriate recycling waste bins wherever possible.





If you wish to finally dispose of the product, ask your local recycling centre or specialist dealer for details about how to do this in accordance with the applicable disposal regulations.



Protect the environment!

Do not dispose of any batteries with general household waste. Return defective or used batteries to your retailer or dispose of them at collection points.

16 Technical data

	Dometic TEC29 EV AUS
Item no.:	9102900291
Rated output voltage:	230 V~ / 50 Hz
Max. constant output (at 25 °C at sea level):	2600 W
Derating altitude:	3.5 % derating every 300 m increase in altitude
Derating temperature:	1 % derating every 5.6 °C increase in temperature.
Battery charger output voltage:	12 V =
Battery charger max. output current:	10 A
Operating temperature range:	-15 °C to +50 °C
Distortion factor:	< 3 %
Fuel:	RON 91 regular grade petrol
Average consumption:	max. 1.2 l/h
Motor output:	4.0 kW (5.5 PS)
Sound level at distance of 7 m:	54 – 59 dB(A)
Dimensions:	see fig. 24 , page 14
Weight:	44 kg
Inspection/certification:	  

AUSTRALIA**Dometic Australia Pty. Ltd.**

1 John Duncan Court · Varsity Lakes QLD 4227

☎ +61 7 1800212121 · 📠 +61 7 55076001

Mail: sales@dometic-waeco.com.au

AUSTRIA**Dometic Austria GmbH**

Neudorferstrasse 108

2353 Guntramsdorf

☎ +43 2236 908070

📠 +43 2236 90807060

Mail: info@waeco.at

BENELUX**Dometic Benelux B.V.**

Ecustraat 3

NL-4879 NP Etten-Leur

☎ +31 76 5029000

📠 +31 76 5029090

Mail: info@dometic.nl

DENMARK**Dometic Denmark A/S**

Nordensvej 15, Taulov

DK-7000 Fredericia

☎ +45 75585966

📠 +45 75586307

Mail: info@waeco.dk

FINLAND**Dometic Finland OY**

Mestarintie 4

FIN-01730 Vantaa

☎ +358 20 7413220

📠 +358 9 7593700

Mail: info@dometic.fi

FRANCE**Dometic SAS**

ZA du Pré de la Dame Jeanne

F-60128 Plailly

☎ +33 3 44633500

📠 +33 3 44633518

Commercial : info@dometic.fr

SAV/Technique : service@dometic.fr

GERMANY**Dometic WAECO International GmbH**

Hollefeldstraße 63 · D-48282 Emsdetten

☎ +49 (0) 2572 879-195 · 📠 +49 (0) 2572

879-322

Mail: info@dometic-waeco.de · Internet:

www.dometic-waeco.de

HONG KONG**WAECO Impex Ltd.**

Suites 2207-2211 · 22/F · Tower 1

The Gateway · 25 Canton Road,

Tsim Sha Tsui · Kowloon

☎ +852 24611386

📠 +852 24665553

Mail: info@dometic-waeco.com.hk

HUNGARY**Dometic Plc. Sales Office**

Kerékgyártó u. 5.

H-1147 Budapest

☎ +36 1 468 4400

📠 +36 1 468 4401

Mail: budapest@dometic.hu

ITALY**Dometic Italy S.r.l.**

Via Virgilio, 3

I-47100 Forlì

☎ +39 0543 754901

📠 +39 0543 756631

Mail: info@dometic.it

NORWAY**Dometic Norway AS**

Skolmar 24

N-3232 Sandefjord

☎ +47 33428450

📠 +47 33428459

Mail: firmapost@waeco.no

POLAND**Dometic Poland Sp. z o.o.**

Ul. Puławska 435A

02-801 Warszawa

☎ +48 22 414 32 00

📠 +48 22 414 32 01

Mail: info@dometic.pl

RUSSIA**Dometic RUS LLC**

Komsomolskaya square 6-1

107140 Moscow

☎ +7 495 780 79 39

📠 +7 495 916 56 53

Mail: info@dometic.ru

SLOVAKIA**Dometic Slovakia Sales Office Bratislava**

Nádražná 34/A

SK-900 28 Ivanka pri Dunaji

☎/📠 +421 2 45 529 680

Mail: bratislava@dometic.com

SPAIN**Dometic Spain S.L.**

Avda. Sierra del Guadarrama, 16

E-28691 Villanueva de la Cañada

Madrid

☎ +34 902 111 042

📠 +34 900 100 245

Mail: info@dometic.es

SWEDEN**Dometic Scandinavia AB**

Gustaf Melins gata 7

S-42131 Västra Frölunda (Göteborg)

☎ +46 31 7341100

📠 +46 31 7341101

Mail: info@waeco.se

SWITZERLAND**Dometic Switzerland AG**

Riedackerstrasse 7a

CH-8153 Rümlang (Zürich)

☎ +41 44 8187171

📠 +41 44 8187191

Mail: info@dometic-waeco.ch

TAIWAN**WAECO Impex Ltd.**

Taipei Office

9F.-10, No. 1180, Zhongzheng Rd.,

Zhonghe Dist., New Taipei City 23586

☎ +886 2 22237225

📠 +886 2 81926742

Mail: marketing@waeco.com.tw

UNITED KINGDOM**Dometic UK Ltd.**

Dometic House · The Brewery

Blandford St. Mary

Dorset DT11 9LS

☎ +44 844 626 0133

📠 +44 844 626 0143

Mail: sales@dometic.co.uk

UNITED ARAB EMIRATES**Dometic Middle East FZCO**

P. O. Box 17860

S-D 6, Jebel Ali Freezone

Dubai

☎ +971 4 883 3858

📠 +971 4 883 3868

Mail: info@dometic.ae

UNITED STATES OF AMERICA**Dometic Marine Division**

2000 N. Andrews Ave. Extension

Pompano Beach, FL 33069 USA

☎ +1 954 973 2477

📠 +1 954 979 4414

Mail: marinesales@dometicus.com